

HiBreak range of low voltage fuse links have been designed to meet the requirements set for modern industrial installations & electrical power plants. Their breaking capacity is sufficient even for the highest short circuit levels, which are normally reached in practice.

The breaking capacity of the fuse links is 80KA at 415AC. The fuse links are suitable for use in both AC/DC applications for over current and short circuit protection and have very low let through energy resulting in reduced electro magnetic stress and reliable short circuit clearance.

They have excellent non-deterioration performance and low power loss values well within the limits of the specification.

Range :

- 2A-630A in Bolted design (BS type)
- 6A-630A in Blade Contact design (DIN type)
- 4A-63A in Round Head design (RH type)

Specification :

Conforms to IEC:60269-1 & 2-1 / IS:13703-1 & 2-1

Features :

- Excellent AC and DC performance
- Low watt loss
- Interchangeable with compatible brands
- ISI Marked



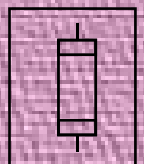



Type	BS (Bolted Connection)	DIN (Blade Contact)	RH (Cylindrical Cap)
Rated Voltage	415 V	415 V	415 V
Rated Current	2A - 630A*	6A - 630A*	4A - 63A*
Rated Frequency	50Hz	50Hz	50Hz
Breaking Capacity	80KA	80KA	80KA
Utilization Category	“gG”	“gG”	“gG”
Non Fusing Current	1.25In	1.25In	1.25In
Fusing Current	1.6In	1.6In	1.6In
Size	F-1, A-2, A-3, A-4 B-1, B2, B-3, B-4 C-1, C-2	CD-000, CD-00, CD-1, CD-2, CD-3	--
Cut-off Characteristics	As per specification	As per specification	As per specification
Material of Body	Steatite ceramic	Steatite ceramic	Steatite ceramic
Material of the Fusing Element	Copper with Tin Solder	Copper with Tin Solder	Copper with Tin Solder
Material of Filler	Silica Quartz	Silica Quartz	Silica Quartz
Material of Blade	Brass (6A - 63A) Copper (80A - 630A)	Brass (6A - 400A) Copper (425-630A)	--
Indication of Blown Fuse	--	Provided	--

* Current Ratings : 2A, 4A, 6A, 10A, 16A, 20A, 25A, 32A, 40A, 50A, 63A, 80A, 100A, 125A, 160A, 200A, 250A, 315A, 350A, 400A, 425A, 500A, 630A.

Time Current Characteristic Curve

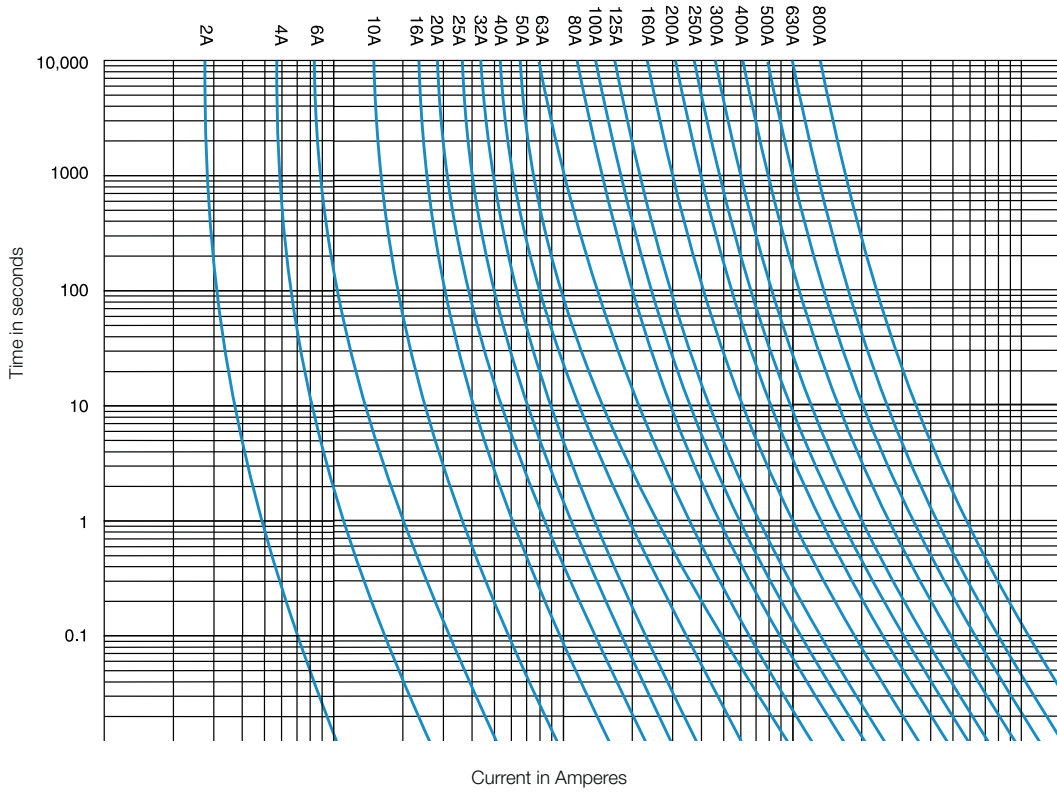

Current Limitation



Fuses are of current limiting design & hence the short circuit currents cannot rise to the full prospective value owing to the very short clearing time. Adverse effects of the short circuit on the switchgear are thus prevented.

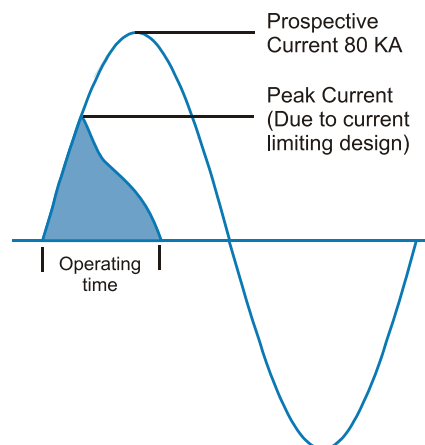

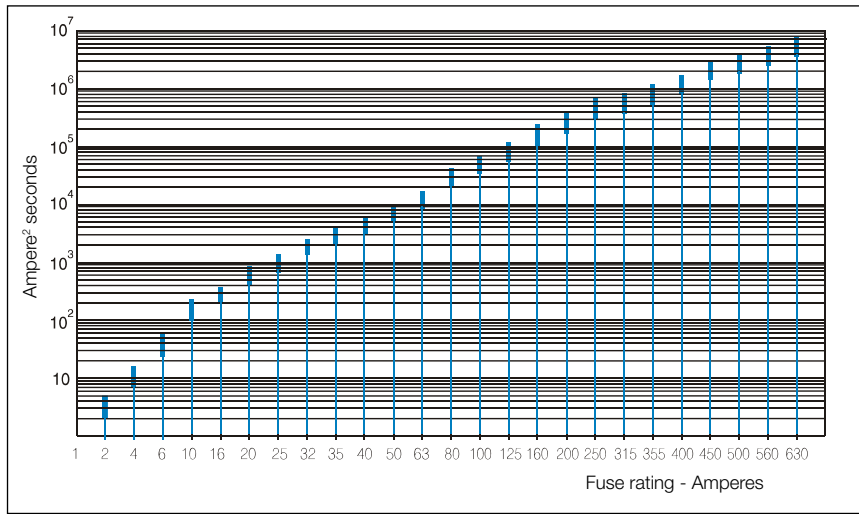

← Total operating I²t
 ← Pre-arcing I²t

Positive discrimination under short-circuit conditions is achieved when the higher rated fuse link is unaffected by the fault current, which can cause the lower rated fuse link to operate. The total operating I²t let through by the lower rated fuse link must be less than the pre-arcing I²t of the higher fuse link.

The I²t characteristics of fuse links with a prospective current upto 80 KA, 0.15 power factor and at 415V AC, is shown for quick selection.

Fuse Selection Table for Motors

Direct On Line Starting			Star Delta Starting		
Motor Rating 3φ, 415V, 50 Hz kW HP		Recommended Fuse Link (Amp)	Motor Rating 3φ, 415V, 50Hz kW HP		Recommended Fuse Link (Amp)
0.37	0.5	4	2.2	3	6
0.55	0.75	4	3.7	5	10
0.75	1	6	5.5	7.5	16
1.1	1.5	6	7.5	10	20
1.5	2	10	9.3	12.5	25
2.2	3	16	11	15	25
3.7	5	20	15	20	32
5.5	7.5	25	18.5	25	50
7.5	10	25	22	30	50
9.3	12.5	32	30	40	63
11	15	50	37	50	80
15	20	63	45	60	100
18.5	25	80	55	75	100
22	30	100	75	100	160
30	40	125	90	125	160
37	50	125	110	150	200
45	60	160	132	180	250
55	75	160	160	215	315
75	100	200	200	270	400
90	125	250	250	335	400
110	150	315			
132	180	400			
160	215	400			
200	270	500			
250	335	500			

BS Type with Bolted Connection



Current Rating (A)	Type	Cat. No.
2, 4, 6, 10, 16, 20, 25, 32	Offset	IHHNS00002-032
2, 4, 6, 10, 16, 20, 25, 32	Offset	IHHTIA0002-032
36, 40, 50, 63	Offset	IHHTSS0036-063
80, 100, 125	Offset	IHHTSD0080-125
80, 100, 125	Central	IHHTSDC080-125
125, 160, 200, 250	Central	IHHTSF0125-250
225, 250, 300, 315	Central	IHHTSK0225-315
400	Central	IHHTSMF400
400	Central	IHHTSMS400
400, 500	Central	IHHTTS0400-500
400, 500	Central	IHHTTM0400-500
630	Central	IHHTLM0630

DIN Type with Blade Contact



Current Rating (A)	Cat. No.
6, 10, 16, 20, 25, 32, 40 50, 63, 80, 100	IHHCD11006-100
6, 10, 16, 20, 25, 32, 40 50, 63, 80, 100	IHHCD00006-100
125	IHHCD00125
160	IHHCD00160
32, 40, 50, 63, 80, 100, 125	IHHCD01032-125
160, 200	IHHCD01160-200
250	IHHCD01250
200, 250, 315	IHHCD02200-315
350, 400	IHHCD02350-400
425	IHHCD03425
500, 630	IHHCD03500-630

RH Type with Cylindrical Cap



Current Rating (A)	Cat. No.
2, 4, 6, 10	IHHRH00002-10
16, 20, 25, 32, 40	IHHRH00016-40
50	IHHRH00050
63	IHHRH00063

BS Type with Bolted Connections

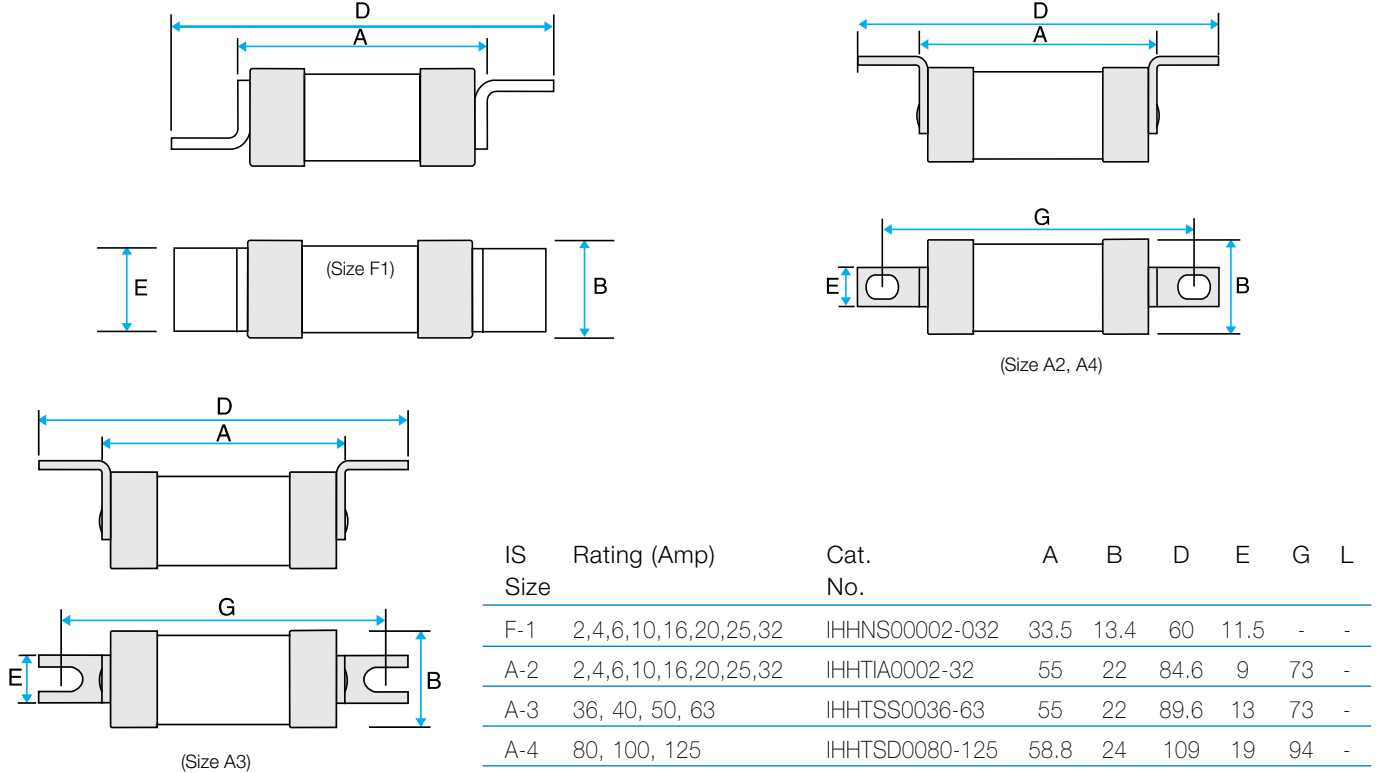

BS Type with Bolted Connections

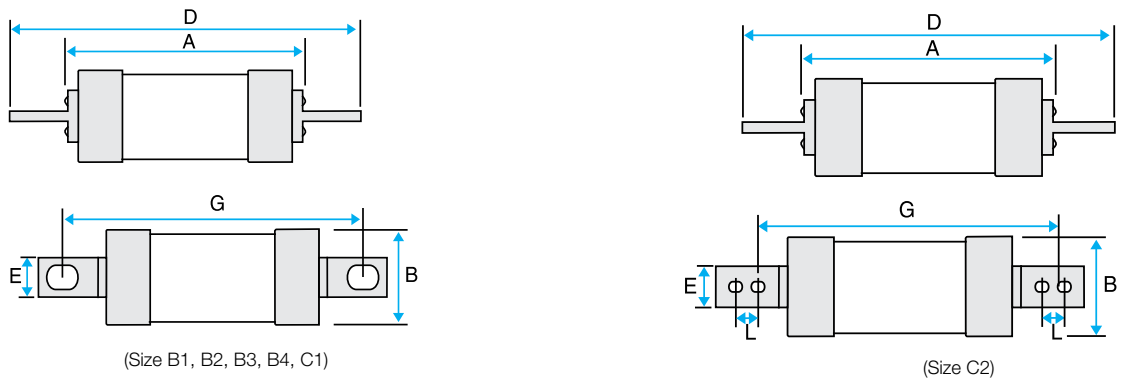

IS size	Rating (Amp)	Cat. No.	A	B	D	E	G	L
B-1	80, 100, 125	IHHTSDC080-125	57	24	134	19	111	-
B-2	125, 160, 200, 250	IHHTSF0125-250	64	33	135	19	111	-
B-3	225, 250, 300-315	IHHTSK0225-315	72.6	39.5	134	25.4	111	-
B-4	400	IHHTSMF400	74.5	51.2	134	25.4	111	-
C-1	400	IHHTSMS400	74.3	51.2	156	25.4	133	-
C-2	400,500	IHHTTS0400-500	72.5	73	164	25.4	133	-
C-2	500, 630	IHHTTM0500-630	72	73	208	25.4	133	25.4

Dimensions (in mm)

RH Type with Cylindrical Cap

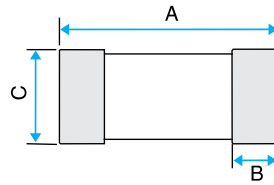

Rating (A)	Cat. No.	A	B	C(ϕ)
2, 4, 6, 10, 16, 20, 25 32, 40, 50, 63	IHHRH	50.5	9.8	14.3

DIN Type with Blade Contacts

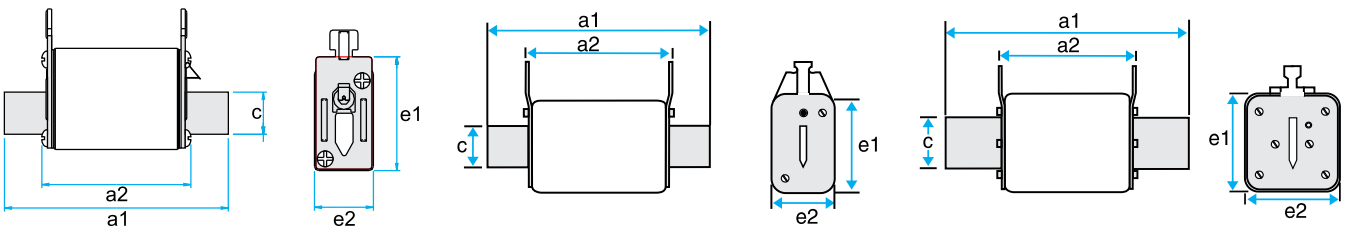

(Size 000)

(Size 00)

(Size 1, 2, 3)

IS Size	Rating (A)	Cat. No.	a ₁	a ₂	c	e ₁	e ₂
000	6,10,16, 20,25,40 32,50,63,80,100	IHHCD***	78.5	52.6	15	43	29.4
00	6,10,16, 20,25,40 32,50,63,80,100,125,160	IHHCD00***	78.5	52.6	15	43	29.4
1	32,40,50,63,80,100 125,160,200,250	IHHCD01***	136	72	20	46	46
2	200,250,315,350,400	IHHCD02***	150	72	25	57	57
3	425,500,630	IHHCD03***	150	72	35	72	72

*** Rating

CD-000

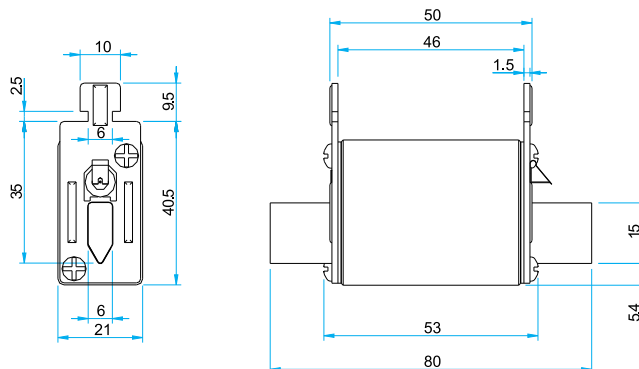

Fuse Bases

Open type fuse bases are available for mounting of DIN type fuse links in current rating 100A, 125A, 160A,250A, 400A and 630A.

These fuse bases conform to IS:13703 & IEC:60269 specification.

Moulding (Casing)

The Bases are manufactured from high grade phenol formaldehyde/ Polyester resin based vinyl moulding compound. These are non-inflammable, non-hygroscopic and with hard glossy black finish.

Contacts

Current carrying parts of the holders are made from precisely pressed copper/brass material and have extruded brass base contacts. These are mounted on moulded seats to ensure perfect alignment. The current carrying parts of the fuse bases are electro plated with silver to ensure long life, non-deteriorating contact surface for high efficiency mating.

Back up Clips

Back up pressure clips have been precisely formed from Phosphor Bronze/Spring Steel materials to ensure perfect mating of male and female parts, for long life.

Terminals

Copper/Brass terminals are used for direct cable termination in case of enclosed type Fuse Holders and through Cable lugs for open type Fuse Bases complete with Cable holding fasteners.

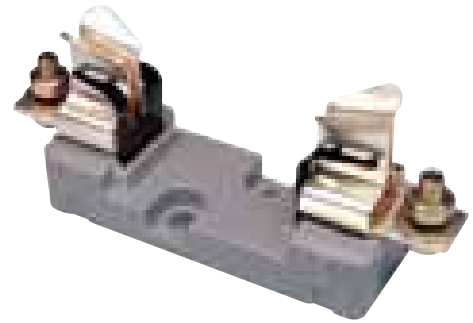

Fuse Holders / Bases

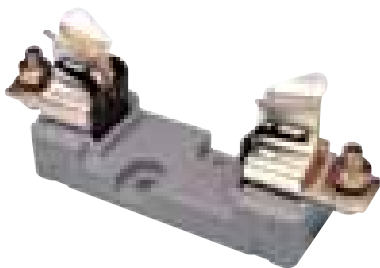

Current Rating (A)	Type	Cat. No.
100A	Open Fuse Base	IHUC000100
125A	Open Fuse Base	IHUC000125
160A	Open Fuse Base	IHUC000160
250A	Open Fuse Base	IHUC010250
400A	Open Fuse Base	IHUC020400
630A	Open Fuse Base	IHUC030630

Dimensions (in mm)

Fuse Bases

125Amps

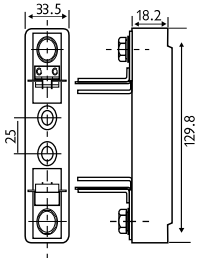

160Amps

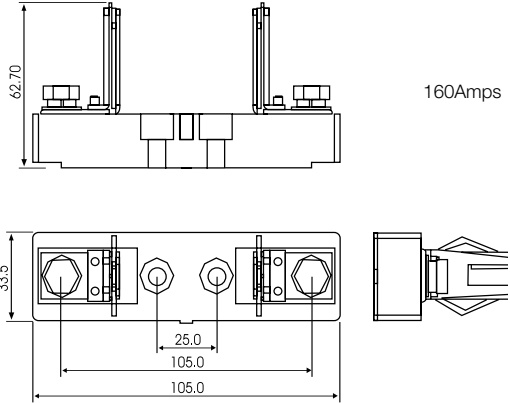

250Amps /
400Amps

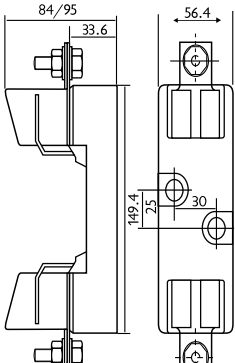

630Amps

